



EXMAS
INTERNATIONAL

EXMAS INTERNATIONAL SOLUTIONS LTD.

➤ **Location:**

Landmark Plaza, Argwings Kodhek Rd, Nairobi

➤ **Company Registration NO:**

REF NO: PVT-BEUEBD5V

➤ **Company KRA Pin**

P052352851B

➤ **Phone No:**

+254714073647 or +254725415177

➤ **Email address**

info@exmasinternationalsolutions.com
director@exmasinternationalsolutions.com

➤ **website**

www.exmasinternationalsolutions.com



Power-Zone™ 4 Arc Resistant Low Voltage Switchgear with ArcBlok™ technology

Description

Page

Low Voltage Switchgear

Power-Zone™ 4 Low Voltage Switchgear with Masterpact™ Circuit Breakers

DE12-2

Power-Zone™ 4 Arc Resistant Low Voltage Switchgear with ArcBlok™ technology

DE12-3



Metalclad Switchgear

Medium Voltage Switchgear

Medium Voltage Metal-Enclosed—MiniBreak™

DE12-4

Medium Voltage Metal-Enclosed —HVL/cc™

DE12-5

Medium Voltage Metal-Enclosed—HVL

DE12-8

Masterclad® Metalclad™; Arc Terminator™

DE12-12

MV Controllers and Substation Circuit Breakers

DE12-13

Switchgear

Low Voltage Metal-Enclosed Drawout
Class 6037 / Refer to Catalogue 6037CT9901



Power-Zone™ 4 low voltage switchgear (class 6037)

Power-Zone™ 4 Low Voltage Switchgear with Masterpact™ Circuit Breakers

The Square D® Power-Zone™ 4 low voltage metal-enclosed drawout switchgear is designed to provide superior electrical distribution, protection, and power quality management. The prime components of the switchgear are the Masterpact™ NW and NT ANSI rated circuit breaker. Power-Zone™ 4 switchgear is designed to maximize the functionality of the Masterpact circuit breakers, which, in turn, deliver maximum uptime, system selectivity, ease of maintenance, and reliable circuit protection. All of these features are packed into the smallest footprint available for low voltage drawout switchgear.

- Power-Zone™ 4 is designed and built to ANSI® C37.20.1, CSA C22.2 No. 31, UL® 1558
- Masterpact™ NW and NT drawout low voltage power circuit breakers are designed and built to ANSI C37.13 and C37.16. Listed to UL 1066
- Short-circuit current rating up to 200 kA at 240Vac, 480Vac and up to 130kA at 600Vac without fuses
- High short-time withstand ratings up to 100 kA for 30 cycles, minimum
- Arc flash limiting (L1F) Masterpact™ NW feeder breakers available in 800, 1600, and 2000 ampere ratings
- Available in Arc Resistant construction certified to ANSI C37.20.7. Please refer to page DE12-3
- Optional Energy reduction maintenance switch
- Family of field installable and upgradeable Micrologic® trip units with optional data communications features
- Power-Zone™ 4 switchgear can offer optional data communications capability:
 - Direct Ethernet Modbus TCP to each Circuit Breaker (IP address per Circuit Breaker)
 - Modbus RS485 from each Circuit Breaker converted to Ethernet Modbus TCP in instrument compartment for customer Modbus TCP connection
 - Modbus RS485 Wired Out to instrument compartment for customer Modbus RS485 connection
- Smallest equipment footprint available in this product class
- Front access to control and communications wire connections
- Bolted copper bus provided as standard (up to 6000 amperes maximum)
- Large rear cable compartment pull area allowing maximum room for power cables
- Horizontal Bus provision for future equipment expansion
- System designed for maximum uptime with low maintenance
- Modular circuit breaker designed for easy addition of control accessories

Masterpact™ NW circuit breakers are available in various levels of interrupting ratings from 42 to 200 kA at 480 volts and up to 130 kA at 600 volts.

The Masterpact™ NT circuit breaker is available in an 800 ampere frame size and 42 kA at 480 volts interrupting rating. Up to 8 Masterpact™ NT circuit breakers can be mounted in a 30-inch wide section. (Not available for 600 volts.)

Circuit breakers of like frame sizes and interrupting ratings are interchangeable.

Rating (A)	Catalogue No.
Masterpact™ NW	
800	NW08N1
	NW08H1
	NW08H2
	NW08H3
	NW08L1
	NW08L1F
1600	NW16N1
	NW16H1
	NW16H2
	NW16H3
	NW16L1
	NW16L1F
2000	NW20H1
	NW20H2
	NW20H3
	NW20L1
	NW20L1F

Rating (A)	Catalogue No.
3200	NW32H1
	NW32H2
	NW32H3
	NW32L1
4000	NW40H2
	NW40H3
	NW40L1
5000	NW50H2
	NW50H3
	NW50L1
6000	NW60H2
	NW60H3
	NW60L1
Masterpact NT	
800	NT08N1

Micrologic® Trip Units

A modern family of field-installable trip units is available with Masterpact NW and NT circuit breakers. The circuit breaker overcurrent protection consists of a microprocessor-based tripping device that requires no external power source. The complete tripping system has three main components: the air-core sensors, the trip device (with rating plug), and the trip actuator. The microprocessor-based trip unit uses true RMS current level sensing.

The Powerlogic® system is used in conjunction with Micrologic Type A, Type P, and Type H trip units for the Masterpact NW and NT circuit breakers. Modbus® industry standard data communications allow the Powerlogic system to replace discrete meters, multiple transducers, analog wires, and analog-to-digital conversion equipment. Extensive information can be transmitted over a single communications cable to a Powerlogic system display, a personal computer, programmable logic controller, or other host system. Basic circuit information, such as amperes, can be monitored using Micrologic Type A trip unit. Circuit breaker remote operation is available using the Micrologic Type P and Type H trip units with Powerlogic functionality. In addition to its metering capabilities, the Micrologic trip unit system is available with optional status inputs and relay outputs for monitoring discrete contacts and remote control of devices by way of the data communications channel.

Micrologic trip unit metering functions include:

- Amperes and volts
- Frequency
- Power
- Power demand
- Energy
- Energy demand
- Power factor
- Power quality measurements
- Communications
- Fault waveform capture
- Waveform capture
- Data logging
- Programmable contacts
- Current unbalance
- Over/under voltage
- Over/under frequency
- Voltage unbalance
- Phase loss
- Phase sequence
- Reverse power
- Long time imaging
- Contact wear indicator
- Masterpact circuit breaker maintenance information



Arc Resistant Power-Zone™ 4
Low Voltage Switchgear
(Class 6037)

Power-Zone™ 4 Arc Resistant Switchgear with ArcBlok™ Technology

Protecting Your Personnel and Equipment from an Arc Flash

Power-Zone™ 4 arc resistant switchgear with Masterpact™ NW ArcBlok™ technology offers patented, superior arc flash protection for operators and maintenance personnel. The arc flash containment features are unique to the industry in both the circuit breaker compartment and the structure.

Power-Zone™ 4 Arc Resistant Switchgear with ArcBlok™ Technology is certified to comply with *ANSI C37.20.7 IEEE Guide for Testing Metal-Enclosed Switchgear Rated Up to 38 kV for Internal Arcing Faults*, and third-party (UL) witnessed as arc resistant switchgear. Refer to Data Bulletin 6037DB1302 for the complete UL Witness Certification Summary.

Features

- Masterpact™ NW circuit breakers with patented ArcBlok™ technology (up to 5000 A)
- Rated for systems with up to 100kA, 635V fault current
- 60 in. (1524 mm) deep x 22 in. (559 mm) wide (smallest arc resistant footprint in the industry)
- 22 in. (559 mm), 36 in. (914 mm) section widths
- 60 in. (1524 mm), 72 in. (1829 mm), 80 in. (2032 mm) section depths
- Internal arc gas management system for optimized cooling
- ANSI Type 2B Rating
- Type 1 enclosures

Available Options

- Insulated copper bus
- High-resistance grounding
- Zone selective interlocking
- Energy reduction maintenance switch
- Section barriers (rear, cable, and side)
- Circuit breaker remote racking
- ANSI Type 2B rated arc plenum exhaust
- Direct Ethernet Modbus TCP connection to each Circuit Breaker (IP address per Circuit Breaker)

Switchgear

Medium Voltage Metal-Enclosed—MiniBreak™ Class 6042 / Refer to Brochure 6042BR9401



MiniBreak™ switch enclosure with door (class 6042)



MiniBreak switch enclosure with fuses (class 6042)

MiniBreak™ Compact Height Switches — 5.5 kV—200 Amperes

The Square D® MiniBreak compact height switch enclosure is only 66-inches high and contains a single 3-pole load interrupter switch, rated 5.5 kV and 200 amperes. Enclosures are free-standing and suitable for both indoor (NEMA 1) and outdoor (NEMA 3R) applications. These switches are available unfused or with provisions for Square D® current-limiting fuses rated from 10E amperes to 200E amperes. Factory-installed accessories include an auxiliary switch, strip heaters, and provisions for a “lock open” only key interlock. The door is mechanically interlocked with the switch operating handle. Set screw cable lugs for #14 solid—2/0 stranded aluminum or copper cable are provided for two line and one load connections. **Fuses are not furnished with this equipment. For fuse information and pricing see table below. The Fused switches and many of the fuses listed below are available from stock.**

Ratings

Max. design voltage (kV)	5.5
BIL (kV)	60
Frequency (Hz)	60
Continuous amperes	200
Interrupting amperes	200
Momentary (amperes asymmetrical)	20,000
Fault close (amperes asymmetrical)	20,000
Capacitor switching (kVAR)	None
Short time, 2 seconds (amperes symmetrical)	12,500
Low frequency withstand (kV)	19
Fuse integrated (symmetrical)	63,000

Note: 1200 horsepower maximum.

Ordering Information

5 kV—200 Ampere Switch

Type	Switch Catalogue No.
Unfused	HVMB305200U
Fused	HVMB305200

- Select switch catalogue number based on fused or unfused.
- Select catalogue numbers for modifications from Factory Modifications table.
- If fused, select 5 kV, 200 amperes maximum current-limiting fuse from table below.
- Price switch and fuses separately. Switches are furnished with provisions only for fuses.
- Weight 450 lbs (204 kg).



Listed metal-enclosed interrupter switchgear

Continuous Current	Fuse Mounting Clip		Catalogue Number
	Size	Centers	
5 kV Fuse			
10E	D	12"	5GS010
15E			5GS015
20E			5GS020
25E			5GS025
30E	D	12"	5GS030
40E			5GS040
50E			5GS050
65E			5GS065
80E			5GS080
100E			5GS100

Continuous Current	Fuse Mounting Clip		Catalogue Number
	Size	Centers	
125E	D	12"	5GS125
150E			5GS150
175E			5GS175
200E			5GS200

Factory Modifications

Catalogue No.	Description
HVM 1	Auxiliary switch, 1-N. . and 1-N.C. contacts
HVM 1	Provisions for lock open only key interlock (does not include the key cylinder—order separately)
HVMH1	Strip heater 100W 120 V
HVMH2	Strip heater with thermostat 100W 120 V
HVMSA3	Distribution class surge arrester (set of three arresters) 3 kV2.55 MC V▲
HVMSA6	Distribution class surge arrester (set of three arresters) 6 kV5.10 MC V▲

▲ Arresters are line side connected.

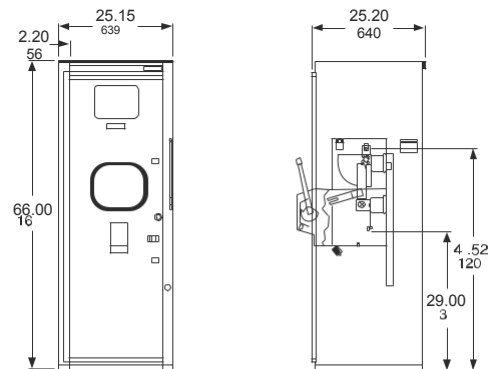

Front view

Section view (unfused)

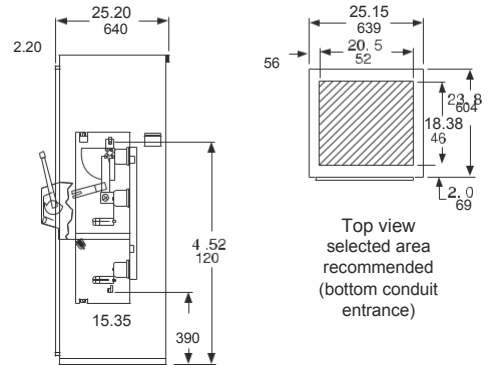

Section view (fused)

Top view selected area recommended (bottom conduit entrance)

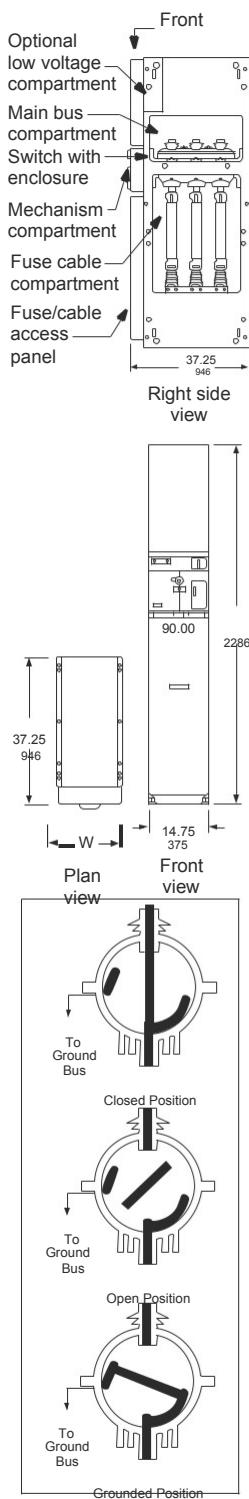

HVL/cc Metal-Enclosed Load Interrupter Switchgear—Full Range

The Square D® HVL/cc metal-enclosed load interrupter switchgear provides switching, metering, and interrupting capabilities for medium voltage electrical power distribution systems and is designed and tested per applicable ANSI/IEEE and NEMA standards.

Made up of modular units, the HVL/cc is easy to expand. Two main bus positions allow future extensions and connections to existing equipment.

HVL/cc switchgear is available in either single or multiple bay units. The design is compact, with front accessibility.

The HVL/cc switch can be equipped with either an over-toggle mechanism (OTM), which is standard, or an optional stored energy mechanism (SEM). An option with both mechanisms is the Fuselogic™ system. The Fuselogic system offers fuse tripping (with SEM) to provide protection against single phasing loads when a fuse has blown. It also has a mechanical interlock to prevent inadvertent switching until fuses have been installed or blown fuses have been replaced.

The HVL/cc enclosure is designed for front access only and can be positioned against walls, in small rooms or in pre-fabricated buildings. The small footprint can result in considerable cost savings from the reduction of building or room sizes.

HVL/cc Load Interrupter Switches— Full Range 600/1200 Ampere Ratings

Switch (kV)— maximum design	5.5	17.5	17.5	25.8	38
BIL (kV)	60	95	110	125	150
Frequency (Hz)	50/60	50/60	50/60	50/60	50/60
Withstand (kV)	19	36	36	50	80
Continuous current (A)	600/1200	600/1200	600/1200	600	600
Interrupting current (A)	600/1200	600/1200	600/1200	600	600
Fault close (kA asymmetrical)	40	40	40	32	32
Momentary current (kA asymmetrical)	40	40	40	32	32
Short time current (kA symmetrical)	25	25	25	25	25
Electrical endurance (at 0 F)	100/600 A	100/600 A	100/600 A	100	100
Mechanical endurance	1000	1000	1000	1000	1000

Switch Standard Features

- Switch Positions: Closed, open, and internally grounded (optional) (connects switch contacts to ground)
- Enclosure: Epoxy
- Medium: Sulphur hexafluoride
- Maintenance: Maintenance free sealed for life
- Pressure:
 - 5.8 PSI (≤ 17.5 kV)
 - 22 PSI (25.8–38 kV)
- View ports to show switch blade position

Options

- Internal ground switch: Has full fault making capability
- Fuselogic™ system
- Infrared viewing windows
- Class I, Division 2
- Fast auto transfers
- Duplex configurations
- Protective relaying
- Powerlogic® metering
- 20-inch or 29.5-inch wide enclosures

Fuselogic™

Fuselogic is a protection system that provides the ultimate in medium voltage fuse protection. This patented system utilizes the Square D® current-limiting fuses with mechanical sensors that function without any auxiliary power requirements. Several combinations of Fuselogic

functions can be combined to provide simple blown fuse indication contacts with mechanical lockout to anti-single phasing protection. Anti-single phasing requires the optional stored energy mechanism (SEM). Fuselogic is available on both HVL/cc and HVL switches.

Switchgear Standard Features

- Compartments: Switch, bus, fuse/cable, mechanism, and optional low voltage/control
- 11 gauge steel enclosure
- Epoxy insulators
- Fuse/cable access panel interlocked with switch
- Front access only
- Animated mechanism mimic bus
- Padlocking open or closed provision
- Top or bottom cable entry
- UL/CUL Listed
- Live line indicators on all incoming switch bays and outgoing feeder circuits
- Cable lugs included for one cable per phase
- Tin plated copper bus for lineups

Surge Arresters

System L-L Voltage kV		Arrester MCOV-kV	
Nominal	Maximum	Effectively Grounded Neutral Circuits	Impedance Grounded and Ungrounded Circuits
2.4	2.54	—	2.55
4.16	4.4	2.55	5.1
4.8	5.08	—	5.1
6.9	7.26	—	7.65
12.0	12.7	7.65	12.70
12.47	13.2	7.65	12.70
13.2	13.97	8.4	—
13.8	14.52	8.4	—

DE12 SWITCHGEAR

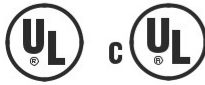

Listed metal-enclosed interrupter switchgear

Switchgear

Medium Voltage Metal-Enclosed —HVL/cc™ Class 6045 / Refer to Catalogue 6045CT9801

NOTE: Cable entry and exit must be opposite to maintain the minimum sections shown.

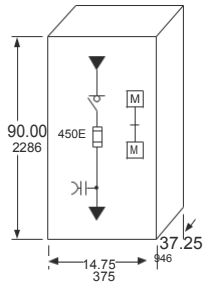

5 kV Indoor N1
top cable in/bottom cable out
switch in Position A

Mechanical interlock between switch and fuse access panel.

NOTE: Mechanical interlock is standard on switches.

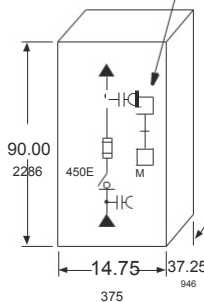

5 kV Indoor N1
top cable in/bottom cable
out switch in position B

HVL/cc Switchgear—Quick Ship Program — 5–15 kV, 600 Amperes

The HVL/cc quick ship program provides basic fused and unfused load interrupter switch configurations for stand-alone or transformer primary applications. The Quick Ship program offers faster delivery, but with fewer options. Three-pole, 600 ampere individual HVL/cc switches are available in free-standing indoor (NEMA 1) enclosures. These switches are available unfused or with provisions for Square D® current-limiting DIN/E fuses. Factory optional accessories include auxiliary bays, main bus, auxiliary switches, extra cable terminating lugs, and distribution class surge arresters. The fuse access panel is mechanically interlocked with the switch mechanism. Key interlocks are not an available option with Digest-listed HVL/cc switches. (1) Set screw type lugs for (2) #2–350 kcmil copper or aluminum cables are provided for line and load connections. **Fuses are not furnished with this equipment. For fuse information and pricing refer to page DE12-5.**

Provisions for Future Expansion

All “single” HVL/cc switches have provisions for future expansion on either side.

Order main bus kits for copper 600 ampere bus. Include sketch for factory-assembled parts or lineups.

600 Ampere Single Switch Unfused

Manual over-toggle mechanism, no grounding switch
Includes (1) set screw lug for (2) #2–350 kcmil Cu or Al conductor per phase
Application A = Top entry (incoming—cable or main bus), bottom exit (load—cable or main bus)
Application B = Bottom entry (incoming—cable or main bus), top exit (load—cable or main bus)

Catalogue No.	kV Rating	Fuse Range	Application	Width	
				in	mm
HVLCCA14305N	4.76	—	A	14.75	375
HVLCCA20305N	4.76	—	A	20.00	508
HVLCCA14315N	15	—	A	14.75	375
HVLCCA20315N	15	—	A	20.00	508
HVLCCB14305N	4.76	—	B	14.75	375
HVLCCB20305N	4.76	—	B	20.00	508
HVLCCB14315N	15	—	B	14.75	375
HVLCCB20315N	15	—	B	20.00	508

600 Ampere Single Switch Fused

(Provisions only for Square D current-limiting DIN/E fuses—order fuses separately)
Manual over-toggle mechanism, no grounding switch
Includes (1) set screw lug for (2) #2–350 kcmil Cu or Al conductor per phase
Application A = Top entry (incoming—cable or main bus), bottom exit (load—cable or main bus)
Application B = Bottom entry (incoming—cable or main bus), top exit (load—cable or main bus)

Catalogue No.	kV Rating	Fuse Range	Application	Width	
				in	mm
HVLCCA14305D	4.76	10–450E	A	14.75	375
HVLCCA20305D	4.76	10–600E	A	20.00	508
HVLCCA14315D	15	10–200E	A	14.75	375
HVLCCA20315D	15	10–360E	A	20.00	508
HVLCCB14305D	4.76	10–450E	B	14.75	375
HVLCCB20305D	4.76	10–600E	B	20.00	508
HVLCCB14315D	15	10–200E	B	14.75	375
HVLCCB20315D	15	10–360E	B	20.00	508

600 Ampere Incoming Line Auxiliary Bay

For bottom incoming cable to application A (bottom cable exit) switch(es)

Order 600 ampere tin plated Cu main bus to adjacent section from bus table

Includes (1) set screw lug for (2) #2–350 kcmil Cu or Al conductor per phase

Catalogue No.	kV Rating	Fuse Range	Application	Width	
				in	mm
HVLCCA14A	4.76/15	—	A	14.75	375
HVLCCA20A	4.76/15	—	A	20.00	508

For top incoming cable to application B (top cable exit) switch(es)

Order 600 ampere tin plated Cu main bus to adjacent section from main bus kits table

Includes (1) set screw lug for (2) #2–350 kcmil Cu or Al conductor per phase

Catalogue No.	kV Rating	Fuse Range	Application	Width	
				in	mm
HVLCCB14A	4.76/15	—	B	14.75	375
HVLCCB20A	4.76/15	—	B	20.00	508

600 Ampere Tin Plated Copper Main Bus Kits

Catalogue No.	Left (From Application)	Width		Right (To Application)	Width	
		in	mm		in	mm
		HVLCCMBA14A14	A		14.75	375
HVLCCMBA14A20	A	14.75	375	A	20.00	508
HVLCCMBA20A14	A	20.00	508	A	14.75	375
HVLCCMBA20A20	A	20.00	508	A	20.00	508
HVLCCMBA14B14	A	14.75	375	B	14.75	375
HVLCCMBA14B20	A	14.75	375	B	20.00	508
HVLCCMBA20B14	A	20.00	508	B	14.75	375
HVLCCMBA20B20	A	20.00	508	B	20.00	508
HVLCCMBB14B14	B	14.75	375	B	14.75	375
HVLCCMBB14B20	B	14.75	375	B	20.00	508
HVLCCMBB20B14	B	20.00	508	B	14.75	375
HVLCCMBB20B20	B	20.00	508	B	20.00	508
HVLCCMBB14A14	B	14.75	375	A	14.75	375
HVLCCMBB14A20	B	14.75	375	A	20.00	508
HVLCCMBB20A14	B	20.00	508	A	14.75	375
HVLCCMBB20A20	B	20.00	508	A	20.00	508

Ratings

HVL/cc Switch with manually operated type OTM mechanism in cubicle enclosure (does not include internal ground switch). Ratings are based on an X/R ratio of 1.6.

Switch (kV)—maximum design BIL (kV)	5.5	17.5
Frequency (Hertz)	60	95
Withstand (kV)	50/60	50/60
	19	36
Continuous current (amperes)	600	600
Interrupting current (amperes)	600	600
Fault close (amperes asymmetrical)	40,000	40,000
Integrated switch and fuse rating (amperes)	65,000	65,000
Momentary current (amperes asymmetrical)	40,000	40,000
Short time current, 2 seconds (amperes symmetrical)	25,000	25,000
Operations at Full Load	100	100
Mechanical Endurance (number of operations)	1000	1000

▲ 50,000 for 630 A fuse.

Factory Modifications

Catalogue No.	Description
HVLCC-X3	Auxiliary switch 2 N.O.—2 N.C. contact

Distribution Class Surge Arresters

(One Set of Three) Switch Load Side Connected or Incoming Line Bay)

Catalogue No.	kV Rating	Section Width Minimum Required	
		in	mm
HVLCCDSA3	3 kV, 2.55 kV MCOV	14.75	375
HVLCCDSA6	6 kV, 5.10 kV MCOV	14.75	375
HVLCCDSA9	9 kV, 7.65 kV MCOV	14.75	375
HVLCCDSA10	10 kV, 8.40 kV MCOV	14.75	375
HVLCCDSA12	12 kV, 10.20 kV MCOV	14.75	375
HVLCCDSA15	15 kV, 12.70 kV MCOV	20.00	508
HVLCCDSA18	18 kV, 15.3 kV MCOV	20.00	508



Listed metal-enclosed interrupter switchgear

Medium Voltage Metal-Enclosed—HVL/cc™ Class 6045 / Refer to Catalogue 6045CT9801

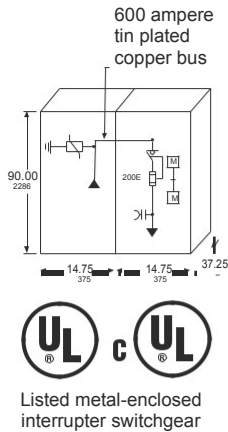

600 Ampere “Single” HVL/cc Switch with PROVISIONS ONLY for Square D® Current-Limiting Non-Disconnect Type Fuses for Cable Connection to Power-Dry™, Power-Cast® and Uni-Cast® Transformers (FLC = 300 Ampere MAXIMUM)
RH—Transformer on right, LH—Transformer on Left Application A = Top Entry (Incoming Cables) Application B = Bottom Entry (Incoming Cables)

Catalogue No.	kV Rating	Fuse Range	Type	Width		RH / LH
				in	mm	
HVLC A14405DGR	4.76	10–450E	A	14.75	375	RH
HVLC A20405DGR	4.76	10–450E	A	20.00	508	RH
HVLC A14405DGL	4.76	10–450E	A	14.75	375	LH
HVLC A20405DGL	4.76	10–450E	A	20.00	508	LH
HVLC A14415DGR	15	10–200E	A	14.75	375	RH
HVLC A20415DGR	15	10–200E	A	20.00	508	RH
HVLC A14415DGL	15	10–200E	A	14.75	375	LH
HVLC A20415DGL	15	10–200E	A	20.00	508	LH
HVLC B14405DGR	4.76	10–450E	B	14.75	375	RH
HVLC B20405DGR	4.76	10–450E	B	20.00	508	RH
HVLC B14405DGL	4.76	10–450E	B	14.75	375	LH
HVLC B20405DGL	4.76	10–450E	B	20.00	508	LH
HVLC B14415DGR	15	10–200E	B	14.75	375	RH
HVLC B20415DGR	15	10–200E	B	20.00	508	RH
HVLC B14415DGL	15	10–200E	B	14.75	375	LH
HVLC B20415DGL	15	10–200E	B	20.00	508	LH

Note: Switches with transformer connections are painted ANSI 49. Standalone switches are painted ANSI 61. Transformer connections in HVL/cc switches are based on Square D® standard transformer connections. If these switches are used to connect to other manufacturers' transformers, then connections must match Square D connections. (Cable connections are furnished with the transformer.)

600 Ampere “Duplex” HVL/cc Switch with PROVISIONS ONLY for Square D Current-Limiting Non-Disconnect Type Fuses for Cable Connection to Power-Dry, Power-Cast and Uni-Cast Transformers (FLC = 300 Ampere MAXIMUM) RH—Transformer on Right, LH—Transformer on Left Includes Mechanical Interlock to Prevent Paralleling of Sources Application A = Top Entry (Incoming Cables) Application B = Bottom Entry (Incoming Cables)

Catalogue No.	kV Rating	Fuse Range	Type	Width		RH/LH
				in	mm	
HVLC A14505DGR	4.76	10–450E	A	14.75	375	RH
HVLC A20505DGR	4.76	10–450E	A	20.00	508	RH
HVLC A14505DGL	4.76	10–450E	A	14.75	375	LH
HVLC A20505DGL	4.76	10–450E	A	20.00	508	LH
HVLC A14515DGR	15	10–200E	A	14.75	375	RH
HVLC A20515DGR	15	10–200E	A	20.00	508	RH
HVLC A14515DGL	15	10–200E	A	14.75	375	LH
HVLC A20515DGL	15	10–200E	A	20.00	508	LH
HVLC B14505DGR	4.76	10–450E	B	14.75	375	RH
HVLC B20505DGR	4.76	10–450E	B	20.00	508	RH
HVLC B14505DGL	4.76	10–450E	B	14.75	375	LH
HVLC B20505DGL	4.76	10–450E	B	20.00	508	LH
HVLC B14515DGR	15	10–200E	B	14.75	375	RH
HVLC B20515DGR	15	10–200E	B	20.00	508	RH
HVLC B14515DGL	15	10–200E	B	14.75	375	LH
HVLC B20515DGL	15	10–200E	B	20.00	508	LH

General Purpose E-Rated Current-Limiting Fuses: Type DIN/E for HVL/cc Switches

Integrated rating for 600 ampere HVL/cc switches with Square D® DIN/E fuses listed below is 65 kA rms symmetrical amperes. (50 kA rms for 630 ampere fuse.) Current-limiting fuses increase the integrated short-circuit current rating because of their energy-limiting capabilities. To increase the short-circuit current rating of the entire lineup of switchgear, current-limiting fuses must be used in the entrance sections.

Catalogue No.	kV Rating	Fuse Rating	Set of Fuses ▲	Fuse Size	Section Width Required	
					in	mm
55DE010	5.5	10E	1	Actual	14.75	375
55DE015	5.5	15E	1	Actual	14.75	375
55DE020	5.5	20E	1	Actual	14.75	375
55DE025	5.5	25E	1	Actual	14.75	375
55DE030	5.5	30E	1	Actual	14.75	375
55DE040	5.5	40E	1	Actual	14.75	375
55DE050	5.5	50E	1	Actual	14.75	375
55DE065	5.5	65E	1	Actual	14.75	375
55DE080	5.5	80E	1	Actual	14.75	375
55DE100	5.5	100E	1	Actual	14.75	375
55DE125	5.5	125E	1	Actual	14.75	375
55DE150	5.5	150E	1	Actual	14.75	375
55DE175	5.5	175E	1	Actual	14.75	375
55DE200	5.5	200E	1	Actual	14.75	375
55DE250	5.5	250E	1	Actual	14.75	375
55DE300	5.5	300E	1	Actual	14.75	375
55DE350	5.5	350E	1	Actual	14.75	375
55DE400	5.5	400E	1	Actual	14.75	375
55DE450	5.5	450E	1	Actual	14.75	375
55DE540	5.5	540A	2	300	20.00	508
55DE600	5.5	630A	2	350	20.00	508
175DE010	15.5	10E	1	Actual	14.75	375
175DE015	15.5	15E	1	Actual	14.75	375
175DE020	15.5	20E	1	Actual	14.75	375
175DE025	15.5	25E	1	Actual	14.75	375
175DE030	15.5	30E	1	Actual	14.75	375
175DE040	15.5	40E	1	Actual	14.75	375
175DE050	15.5	50E	1	Actual	14.75	375
175DE065	15.5	65E	1	Actual	14.75	375
175DE080	15.5	80E	1	Actual	14.75	375
175DE100	15.5	100E	1	Actual	14.75	375
175DE125	15.5	125E	1	Actual	14.75	375
175DE150	15.5	150E	1	Actual	14.75	375
155DE175	15.5	175E	1	Actual	14.75	375
155DE200	15.5	200E	1	Actual	14.75	375
155DE225	15.5	225A	2	125	20.00	508
155DE270	15.5	270A	2	150	20.00	508
155DE315	15.5	315A	2	175	20.00	508
155DE360	15.5	360A	2	200	20.00	508

▲ Each (1) set of fuses contains three fuses. (E.g., (2) sets of fuses yield a total of six fuses.)

Ordering Information

- Select switch catalog number based on fused or unfused and cable entry locations (top or bottom) from table on page DE12-4.
- Select incoming line auxiliary bay from table on page DE12-4, if required.
- Select main bus from table on page DE12-4, if required.
- Select catalog numbers for factory modifications from table on page DE12-4, if required.
- If fused, select DIN/E fuses.

DE12 SWITCHGEAR

Switchgear

Medium Voltage Metal-Enclosed—HVL Class 6040 / Refer to Catalogue 6040CT9201 or Handout

HVL Metal-Enclosed Load Interrupter Switchgear—Full Range

HVL™ 5–38 kV Load Interrupter is the most popular ANSI-rated switchgear in its class in America. Among medium voltage interrupter switchgear, both the switch and the enclosure stand as industry benchmarks in the areas of design, manufacturing, and performance. Load interrupter switchgear must perform a number of critical functions in a unit substation - protecting equipment and disconnecting faulted lines and transformers. Designed and tested to the latest applicable standards, HVL has been engineered to provide superior protection for your distribution system.

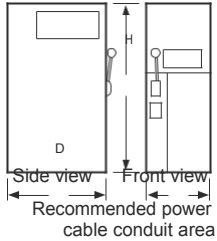

2.00 38.00 2.00
51 51

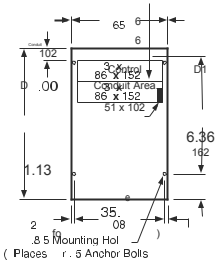

HVL switchgear is available for Various applications and configurations, including:

- Individual service entrance bays
- Multiple-bay lineups incorporating HVL load interrupters and optional Visi/Vac® circuit interrupters

Square D® metal-enclosed switchgear has become an industry standard for its better system

performance, lower maintenance cost, easier system expansion, and reduced system expense.

A full range of ratings and options are available but not listed in this publication. Contact your nearest Exmas International Solutions Electric sales office or your local Exmas International Solutions Electric distributor.

Ratings

Maximum design voltage (kV)	15	25.8	38
BIL (kV)	60	125	150
Frequency (Hz)	50/60	50/60	50/60
Continuous amperes	600/1200	600	600
Interrupting amperes Momentary (kA asymmetrical)	600/1200	600	600
Fault close (kA asymmetrical)	0/61	0	0
Capacitor switching (kVAR)	2 00	2 00	—
Short time rating 2 seconds (kA symmetrical)	25/38/50	25/38/50	25
Low frequency withstand (kV)	1	36	60

Standard Features

- 11 gauge steel enclosure
- Direct drive mechanism
- Permanently attached operating handle
- Visible isolation viewing window
- Mechanical interlocked fuse access door
- Provision for padlock and key interlock
- Highly flexible design
- ANSI 61 paint

Options

- Outdoor construction
- Square D® DIN-style current-limiting fuses
- Boric acid fuses
- Silver or tin plated copper bus
- 600, 1200 or 2000 ampere main bus
- Heat shrink insulated bus
- Motor operator
- Shunt trip
- Fuselogic™ tripping system
- Automatic load transfer schemes
- Roof bushings
- Key interlocks
- Surge arresters

- Utility metering bays
- Line selector switch
- Duplex switch
- Transformer connections
- Infrared windows for thermal scanning of connections

Fuselogic™

Fuselogic is a protection system that provides the ultimate in medium voltage fuse protection. This patented system utilizes the Square D® current-limiting fuses with mechanical sensors that function without any auxiliary power requirements. Several combinations of Fuselogic functions can be combined to provide simple blown fuse indication contacts with mechanical lockout to anti-single phasing protection. Anti-single phasing requires the optional stored energy mechanism (SEM). Fuselogic is available on both HVL/cc™ and HVL switches.

HVL Switchgear—Quick Ship Program— 5 kV–15 kV, 600 Ampere Features

The HVL quick ship program provides basic fused and unfused load interrupter switch configurations for stand-alone or transformer primary applications. The Quick Ship program offers faster delivery, but with fewer options.

Three-pole, 600 ampere individual HVL switches are available in free-standing indoor (NEMA 1) or outdoor (NEMA 3R) enclosures. The switches used in these enclosures are UL Recognized and are listed under Category IQ 2 in File E1 05 1(M). These switches are available unfused or with provisions for 3-inch

diameter Square D® current-limiting fuses or for boric acid fuses. Factory optional accessories include auxiliary switches, extra cable terminating lugs and distribution class surge arresters. The door is mechanically interlocked with the switch operating handle and provisions for key interlocks are standard.

Set screw type lugs for one 2solid 600 kcmil copper or aluminum cables are provided for line and load connections. Other standard features include a bolted enclosure with a viewing window, ground pad, and space heater (NEMA 3R only). Control power for heater must be from external source. **Fuses are not furnished with this equipment. For fuse information, refer to page DE12-8. Switches are listed on pages DE12-6–DE12-7, and many of the fuses listed on page DE12-9 are available from stock.**

600 Ampere “Single” Switch Unfused

Catalogue No.	kV Rating	Fuse Range	Enclosure Type
<i>New!</i> HVL305N	.6		NEMA 1
HVL305N	.6		NEMA 3R
HVL315N	15		NEMA 1
HVL315N	15		NEMA 3R

600 Ampere “Single” Switch with PROVISIONS ONLY for Square D Current-Limiting Non-Disconnect Type Fuses

Catalogue No.	kV Rating	Fuse Range	Enclosure Type
HVL305DE	.6	10–50E	NEMA 1
HVL305DE	.6	10–50E	NEMA 3R
HVL315DE 1	15	10–100E	NEMA 1
HVL315DE 2	15	125–200E	NEMA 1
HVL315DE 1	15	10–100E	NEMA 3R
HVL315DE 2	15	125–200E	NEMA 3R

600 Ampere “Single” Switch with PROVISIONS ONLY for S&C Boric Acid Non-Disconnect Type Fuses

Catalogue No.	kV Rating	Fuse Range	Enclosure Type
HVL305B	.6	10E–00E	NEMA 1
HVL305B	.6	10E–00E	NEMA 3R
HVL315B	15	10E–00E	NEMA 1
HVL315B	15	10E–00E	NEMA 3R
HVL31 B	1	10E–00E	NEMA 1
HVL31 B	1	10E–00E	NEMA 3R



Listed metal-enclosed interrupter switchgear

Ratings

Max. Design Voltage (kV)	4.76	15.0
BIL (kV)	60	95
Frequency (Hz)	50/60	50/60
Continuous amperes	600	600
Interrupting amperes	600	600
Momentary (amperes asymmetrical)	40,000	40,000
Fault close (amperes asymmetrical)	40,000	40,000
Capacitor switching (kVAR)	2,400	2,400
Short-time rating, 2 seconds (amperes symmetrical)	25,000	25,000
Low frequency withstand (kV)	19	36

Distribution Class Surge Arresters

System L-L Voltage kV		Arrester MCOV-kV	
Nominal	Maximum	Effectively Grounded Neutral Circuits	Impedance Grounded and Ungrounded Circuits
2.4	2.54	—	2.55
4.16	4.4	2.55	5.1
4.8	5.08	—	5.1
6.9	7.26	—	7.65
12.0	12.7	7.65	12.70
12.47	13.2	7.65	12.70
13.2	13.97	8.4	—
13.8	14.52	8.4	—

Enclosure Type

Type	W		D		H		Weight	
	in	mm	in	mm	in	mm	lbs	kg
Indoor	38.00	965	54.50	1384	90.00	2286	1200	545
Outdoor	38.00	965	60.00	1524	97.50	2477	1400	636

Provisions for Future Expansion

All "single" Digest switches have provisions for future expansion on either side. Order kits HVMB for top crossover copper 600 ampere bus and HVLC for line connections to the top bus. (Refer to the Factory Modifications table on page DE12-8.) Include sketch for factory-assembled parts or lineups.

600 Ampere "Single" Switch with PROVISIONS ONLY for Square D Current-Limiting Non-Disconnect Type Fuses for Cable Connection to Power-Dry, Power-Cast and Uni-Cast Transformers (FLC = 300 Ampere MAXIMUM)

RH—Transformer on Right, LH—Transformer on Left

Catalogue No.	kV Rating	Fuse Range	Enclosure Type	RH/LH
<i>New!</i>				
HVL405DEGR	4.76	10–450E	NEMA 1	RH
HVL405DEGL	4.76	10–450E	NEMA 1	LH
HVL405DEWRH	4.76	10–450E	NEMA 3R	RH
HVL405DEWLH	4.76	10–450E	NEMA 3R	LH
HVL415DEGR1	15	10–100E	NEMA 1	RH
HVL415DEGR2	15	125–200E	NEMA 1	RH
HVL415DEGL1	15	10–100E	NEMA 1	LH
HVL415DEGL2	15	125–200E	NEMA 1	LH
HVL415DEWR1H	15	10–100E	NEMA 3R	RH
HVL415DEWR2H	15	125–200E	NEMA 3R	RH
HVL415DEWL1H	15	10–100E	NEMA 3R	LH
HVL415DEWL2H	15	125–200E	NEMA 3R	LH

600 A "Duplex" Switch with PROVISIONS ONLY for SQUARE D Current-Limiting Non-Disconnect Type Fuses for Cable Connection to Power-Dry, Power-Cast and Uni-Cast Transformers (FLC = 300 Ampere MAXIMUM)

RH—Transformer on Right, LH—Transformer on Left

Catalogue No.	kV Rating	Fuse Range	Enclosure Type	RH/LH
HVL505DEGR	4.76	10–450E	NEMA 1	RH
HVL505DEGL	4.76	10–450E	NEMA 1	LH
HVL505DEWRH	4.76	10–450E	NEMA 3R	RH
HVL505DEWLH	4.76	10–450E	NEMA 3R	LH
HVL515DEGR1	15	10–100E	NEMA 1	RH
HVL515DEGR2	15	125–200E	NEMA 1	RH
HVL515DEGL1	15	10–100E	NEMA 1	LH
HVL515DEGL2	15	125–200E	NEMA 1	LH
HVL515DEWR1H	15	10–100E	NEMA 3R	RH
HVL515DEWR2H	15	125–200E	NEMA 3R	RH
HVL515DEWL1H	15	10–100E	NEMA 3R	LH
HVL515DEWL2H	15	125–200E	NEMA 3R	LH

600 Ampere "Single" Switch with PROVISIONS ONLY for S&C Boric Acid Non-Disconnect Type Fuses for Cable Connection to Power-Dry, Power-Cast and Uni-Cast Transformers ▲

(FLC = 300 Ampere MAXIMUM)

RH—Transformer on Right, LH—Transformer on Left

Catalogue No.	kV Rating	Fuse Range	Enclosure Type	RH/LH
HVL405BGR	4.76	10E–400E	NEMA 1	RH
HVL405BGL	4.76	10E–400E	NEMA 1	LH
HVL405BWRH	4.76	10E–400E	NEMA 3R	RH
HVL405BWLH	4.76	10E–400E	NEMA 3R	LH
HVL415BGR	15	10E–400E	NEMA 1	RH
HVL415BGL	15	10E–400E	NEMA 1	LH
HVL415BWRH	15	10E–400E	NEMA 3R	RH
HVL415BWLH	15	10E–400E	NEMA 3R	LH

600 Ampere "Duplex" Switch with PROVISIONS ONLY for S&C Boric Acid Non-Disconnect Type Fuses for Cable Connection to Power-Dry, Power-Cast and Uni-Cast Transformers ▲

(FLC = 300 Ampere MAXIMUM)

RH—Transformer on Right, LH—Transformer on Left

Catalogue No.	kV Rating	Fuse Range	Enclosure Type	RH/LH
HVL505BGR	4.76	10E–400E	NEMA 1	RH
HVL505BGL	4.76	10E–400E	NEMA 1	LH
HVL505BWRH	4.76	10E–400E	NEMA 3R	RH
HVL505BWLH	4.76	10E–400E	NEMA 3R	LH
HVL515BGR	15	10E–400E	NEMA 1	RH
HVL515BGL	15	10E–400E	NEMA 1	LH
HVL515BWRH	15	10E–400E	NEMA 3R	RH
HVL515BWLH	15	10E–400E	NEMA 3R	LH

▲ Includes fuse holder only. See table on page DE12-9 for fuse refills.
Note: Switches with transformer connections are painted ANSI 49. Standalone switches are painted ANSI 61.

Switchgear

Medium Voltage Metal-Enclosed—HVL Class 6040 / Refer to Catalogue 6040CT9201

Fuse Selection

The rule of thumb method for selecting fuses for transformer protection is 1.33 times the self-cooled full load current of the transformer or the next higher fuse rating. Selection of the fuse is the customer's responsibility and should be based on transformer and system characteristics.

- **Maximum Fuse Size:**

Maximum fuse size should be determined by comparing the fuse total clearing curve to the transformer damage curve. Contact Exmas International Solutions Electric for transformer overload and short-circuit withstand capability.

- **Minimum Fuse Size:**

Minimum fuse size shall carry the transformer magnetizing inrush current of 12 times full load amperes for 0.1 second.

Factory Modifications

Catalogue No.	Description
HVMB	Main Bus Kit, 600 ampere copper
HVLC	Line side connector kit (main bus) 600 amperes with 2-1/0=500 MCM lugs (top only)
	Provisions for key interlocks (does not include key cylinders—order separately)
HVLX3	Auxiliary switch 2 N.O.—2 N.C. contact
HVLC2	Set screw type lugs 1/0—500 kcmil (qty. 3)

Distribution Class Surge Arresters ▲

HVDSA3	3 kV, 2.55 MCOV
HVDSA6	6 kV, 5.10 MCOV
HVDSA9	9 kV, 7.65 MCOV
HVDSA10	10 kV, 8.40 MCOV
HVDSA12	12 kV, 10.20 MCOV
HVDSA15	15 kV, 12.70 MCOV

▲ Load side connected

Standard Features

- Switches for transformer primaries are cable connected only.
- Key interlocks must be ordered and coordinated by customer.
- Standard color is ANSI 61 for stand alone units;
- ANSI 49 for switches connecting to transformers.
- If switches are purchased to coordinate with Square D[®] transformers, composite drawings and shipment coordination will not be available.
- Switches are not designed for any special dimensions for retrofit purposes. For dimensions other than shown, contact your nearest Exmas International Solutions Electric sales office or your local Exmas International Solutions Electric distributor.

Ordering Information

1. Select switch catalog number based on fused or unfused and enclosure type.
2. Select catalog numbers for factory modifications from the table above.
3. If fused, select fuse from table on page DE12-9.
4. Price switch and fuses separately. Switches are furnished with provisions only for current-limiting fuse or boric acid fuse.

Medium Voltage Metal-Enclosed—HVL Class 6040 / Refer to Catalogue 6040CT9201

Square D® DIN/E Fuse Selection Tables—HVL

DIN/E Current-Limiting Fuses Non-Disconnecting Type ▲◆
(Extended travel blown fuse indicator)

(Contact your nearest Exmas International Solutions Electric sales office for current stock quantities.) One Set of Three Packed in One Box.

Continuous Current	Fuse Mounting Clip ■		Catalogue No. <i>New!</i>
	Centers (in)	Diameter (mm)	
5 kV Fuse			
10E	17.4	51	55DE010
15E	17.4	51	55DE015
20E	17.4	51	55DE020
25E	17.4	51	55DE025
30E	17.4	51	55DE030
40E	17.4	51	55DE040
50E	17.4	51	55DE050
65E	17.4	51	55DE065
80E	17.4	51	55DE080
100E	17.4	51	55DE100
125E	17.4	76	55DE125
150E	17.4	76	55DE150
175E	17.4	76	55DE175
200E	17.4	76	55DE200
250E	17.4	76	55DE250
300E	17.4	76	55DE300
350E	17.4	76	55DE350
400E	17.4	76	55DE400
450E	17.4	76	55DE450
15 kV Fuse			
10E	17.4	51	175DE010
15E	17.4	51	175DE015
20E	17.4	51	175DE020
25E	17.4	51	175DE025
30E	17.4	51	175DE030
40E	17.4	76	175DE040
50E	17.4	76	175DE050
65E	17.4	76	175DE065
80E	17.4	76	175DE080
100E	17.4	88	175DE100
125E	21.14	88	175DE125
150E	21.14	88	175DE150
175E	21.14	88	175DE175
200E	21.14	88	175DE200

- ▲ Square D® DIN/E fuses are shown in this table. For fuses produced by other manufacturers, contact your nearest Exmas International Solutions Electric sales office or your local Exmas International Solutions Electric distributor.
- All fuses are single barrel arrangement with ferrule diameters per the chart.
- ◆ Current-limiting fuses will increase the integrated short-circuit ratings beyond the non-fusible units. Contact your nearest Exmas International Solutions Electric sales office or your local Exmas International Solutions Electric distributor.

Fuse Selection Tables Boric Acid Fuses—HVL

(Contact your nearest Exmas International Solutions Electric sales office for current stock quantities.) One Set of Three Packed in One Box.

	Fuse Type ▼	Catalogue No.	Fuse Type △	Catalogue No.
5 kV Fuse Refill				
10E	SM-5S	5SM5010	RBA400	405WBAF010
15E	SM-5S	5SM5015	RBA400	405WBAF015
20E	SM-5S	5SM5020	RBA400	405WBAF020
25E	SM-5S	5SM5025	RBA400	405WBAF025
30E	SM-5S	5SM5030	RBA400	405WBAF030
40E	SM-5S	5SM5040	RBA400	405WBAF040
50E	SM-5S	5SM5050	RBA400	405WBAF050
65E	SM-5S	5SM5065	RBA400	405WBAF065
80E	SM-5S	5SM5080	RBA400	405WBAF080
100E	SM-5S	5SM5100	RBA400	405WBAF100
125E	SM-5S	5SM5125	RBA400	405WBAF125
150E	SM-5S	5SM5150	RBA400	405WBAF150
175E	SM-5S	5SM5175	—	—
200E	SM-5S	5SM5200	RBA400	405WBAF200
250E	SM-5S	5SM5250	RBA400	405WBAF250
300E	SM-5S	5SM5300	RBA400	405WBAF300
400E	SM-5S	5SM5400	RBA400	405WBAF400
15 kV Fuse Refill				
10E	SM-5S	15SM5010	RBA400	415WBAF010
15E	SM-5S	15SM5015	RBA400	415WBAF015
20E	SM-5S	15SM5020	RBA400	415WBAF020
25E	SM-5S	15SM5025	RBA400	415WBAF025
30E	SM-5S	15SM5030	RBA400	415WBAF030
40E	SM-5S	15SM5040	RBA400	415WBAF040
50E	SM-5S	15SM5050	RBA400	415WBAF050
65E	SM-5S	15SM5065	RBA400	415WBAF065
80E	SM-5S	15SM5080	RBA400	415WBAF080
100E	SM-5S	15SM5100	RBA400	415WBAF100
125E	SM-5S	15SM5125	RBA400	415WBAF125
150E	SM-5S	15SM5150	RBA400	415WBAF150
175E	SM-5S	15SM5175	—	—
200E	SM-5S	15SM5200	RBA400	415WBAF200
250E	SM-5S	15SM5250	RBA400	415WBAF250
300E	SM-5S	15SM5300	RBA400	415WBAF300
400E	SM-5S	15SM5400	RBA400	415WBAF400

- ▼ S&C Boric Acid Fuses
Type SM-5S fuses are manufactured by the S&C Electric Company. SM-5S has a 25.0 kA symmetrical short-circuit rating from 2.4 kV to 17.0 kV. For 16.5 kV ratings, only S&C boric acid fuses can be used.
- △ Cutler-Hammer - Westinghouse Fuses
Type RBA-400 fuses are manufactured by Cutler-Hammer - EATON Corporation. RBA-400 has a 37.5 kA symmetrical ampere short-circuit rating from 2.4 kV to 4.8 kV and 29.4 kA symmetrical from 12 kV to 13.8 kV.

Switchgear

Masterclad[®] Metalclad[™] (UL Listed) Arc Terminator[™]
 Class 60 Refer to Catalogue 60 CT 01 or Brochure



Two-high Masterclad 5–27 kV Metalclad switchgear



Vacuum VR circuit breaker for Masterclad switchgear



Two-high Masterclad 5–27 kV Metalclad switchgear



Arc-Terminator[™] arc extinguishing system



CSA listed switchgear *

* Breakers do not have a CSA standard to list to.

Masterclad[®] Medium Voltage Metalclad[™] Switchgear (UL Listed)

The Reliability of a Quality Design

The quality of Square D[®] Masterclad medium voltage Metalclad switchgear stems from a design and manufacturing process that focuses on long-term switchgear performance with the highest degree of reliability.

Based on specific customer application needs, Exmas International Solutions Electric engineers and technicians select the appropriate standard sections and bus configurations, with the ability to customize where needed. After the specified circuit breakers, instrument and control power transformers, relays, meters and other components are selected and approved. All are factory-assembled, wired, and tested as a complete assembly.

Ratings

Nominal voltage (kV)	4.16	7.2	13.8	24.9				
Maximum voltage (kV)	4.76	8.25	15.0	27.0				
BIL (kV)	60	95	95	125				
Frequency (Hz)	50/60	50/60	50/60	50/60				
Continuous amperes (A)	1200–3000	1200–3000	1200–3000	1200–2000				
MVA (reference only)	250–350	500	500–750–1000	1250–2000				
Short-time rating (kA) 3 seconds	36	49	41	23	36	48	25	40
Close and latch rating (kA) (peak)	97	132	111	62	97	130	68	108

Type VR Vacuum Circuit Breaker

The VR breaker is a horizontal drawout type designed to provide long life, reduced maintenance, and ease of handling. The Type RI advanced design motor-charged stored energy mechanism is a model of reliability with simplicity-with an operating life exceeding ANSI requirements. The VR circuit breaker is UL labeled and includes a permanently mounted manual charging handle.

Switchgear Construction

- Floor mounted breaker racking mechanism
- Standard epoxy supports or optional porcelain supports
- Aluminum or copper main bus
- Indoor NEMA 1
- Outdoor NEMA 3R
- Walk-in
- Non walk-in

New!

Arc Terminator[™] Arc Extinguishing System

Active system detects and controls the effects of internal arcing faults. It complies with ANSI C37.20.7 requirements for arc resistant switchgear for Type 1, Type 2, and Type 2A.

Benefits

- Prevents pressure buildup
- Reduces release of toxic materials
- Eliminates need for reinforced switchgear
- Eliminates special requirements for buildings or plenums
- Minimizes equipment damage
- Reduces operating downtime

SF₆ Circuit Breakers



LF



SF1



SF2

The LF and SF Series of SF₆ Medium Voltage circuit breakers are available for the following ratings

Rated Voltage	5 to 38 kV
Rated Current	600 to 3000 A
Insulation Level	up to 200 kV
Standards	ANSI and IEC

Please contact Marketing for further information.



Listed Controllers



Motorpact™ Medium Voltage Motor Controllers (UL Listed)

Square D® Motorpact medium voltage motor controllers are designed and manufactured to tackle the toughest power and process control challenges. Our motor controllers feature industry-first innovations that provide unmatched performance, high reliability, low maintenance and exclusive technologies. Motorpact medium voltage motor controllers are designed to provide the most efficient means to control and protect a wide range of applications and may be configured for motor starting, transformer feeders, capacitor feeders or future spaces.

Motorpact controllers are designed to meet or exceed the standards for NEMA ICS3 Part 2, UL Standard 347, and IEC 60470. UL and cULus labels are standard.

Starting application for squirrel cage induction motors:

- Full voltage non-reversing
- Full voltage reversing
- Reduced voltage non-reversing
 - Auto transformers
 - Solid state soft start

Enclosures are available in Type 1, 1A, and 3R and feature the smallest footprint in the industry at 14.75 inches wide. Enclosures that are 20-inches and 29.5-inches wide are also available for FVNR.

Optional arc resistant Type 2 enclosures are also available.

Units are designed as one-high construction for ease of use with a optimum height for the operator controls and isolation switch disconnect handle.

Full front and or front and rear accessibility are provided. A full height cable pulling area is standard.

Controller voltage ratings range from 2.3–7.2 kV vacuum contactors feature a drawout design and have ratings of 200, 400, 450, and 720 amperes.

Options include live line indicators, blown fuse tripping, solid state protective relays, power factor correction capacitors, surge arresters, surge capacitors and a cable grounding switch.

Powersub® Vacuum Substation Circuit Breaker Type FVR (Not UL Listed)

By combining the latest developments in circuit breaker technology with world-renowned quality, Powersub vacuum substation circuit breakers are the most advanced medium voltage circuit breakers available. The Type FVR Powersub circuit breakers include arc-resistant construction and are built to comply with ANSI standards.

Features and Ratings

- Voltage—15–38 kV
- 110–200 kV BIL
- Ampere Ratings—600, 800, 1200, 2000, 3000, 3500 and 4000
- Interrupting amperes—12.5–40 kA (rms symmetrical)
- Arc resistant enclosure construction, 2000 amperes and below, based on EEMAC and IEC test standards
- No fans required for 3000 ampere ratings
- Interrupting time of three (3) cycles
- Hermetically sealed vacuum interrupters

The arc-resistant design takes safety to the next level. In the event of an arc, the arc-resistant construction provides increased safety for personnel working in proximity of the breaker by venting resultant arc by-products and ionized gases upward and away from exterior panels that otherwise may not remain intact and in place. The Powersub circuit breakers also provide superior protection as a result of their high speed operation. You can expect long life from the product as the vacuum interrupter contacts are protected from corroding elements and contamination.

Switchgear

Load Break Interrupter Switches -
Refer to Document C-3-512

Load Interrupter Switches 4.16 through 34.5 kV

For cost efficiency and versatility select an FPL Type NAL load break switch. It can be provided with numerous options including motor driven operating mechanism

Type	NAL 5	NAL 7	NAL 15	NAL 15.5	NAL 25	NAL 35
Nominal Voltage Rating kV	4.16	7.2	13.8	14.4	25.0	34.5
Maximum Rated Voltage kV	4.76	8.25	15.0	15.5	29.8	38.0
Continuous Current (Amperes)	600, 1200	600, 1200	600, 1200	600, 1200	600, 1200	600
Impulse Test Voltage (BIL)	60	75	95	110	125	150

For further information refer to Bulletin No. C-3-512.

The type NAL 3 pole, load interrupter switch is suitable for use as a main or feeder load interrupter switch or as a primary protective device when fitted with fuses. The type NAL switch can be used in conjunction with current-limiting fuses or expulsion type power fuses.

The NAL switch is available with either a quick make, quick break mechanism, or with the same characteristics and a spring stored energy mechanism which allows the switch to be tripped remotely or used in conjunction with protective relays. The switch can also be automatically tripped after operation of a striker-pin equipped fuse to prevent single phasing. Optional features include motor operators for all types of operating mechanisms, blown fuse single phase protection, and mechanically interlocked grounding switch, Type EB.

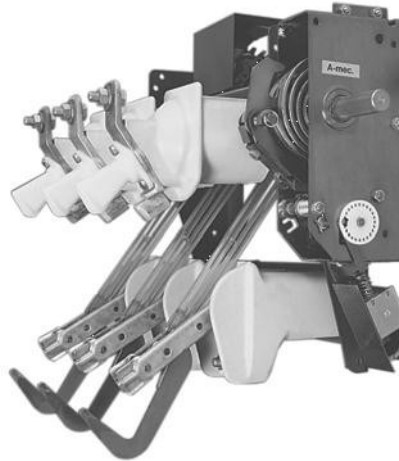

Type NAL 3 Pole Load Interrupter Switch



Listed